

EN

DECLARATION OF PERFORMANCE

No. PEC-TA_2451-CPR-EAD-2017.0004

1. Unique identification code of the product-type:

Hilti anchor channels (PEC-TA) with channel bolts (HBC)

2. Intended use/es:

Product	Intended use
Anchor Channel	For fixing and/or supporting to concrete, structural elements (which contributes to the stability of the works) or heavy units.

3. Manufacturer:

Hilti Werke

4. System/s of AVCP: System 1

5. European Assessment Document: EAD 330008-03-0601

European Technical Assessment: ETA-16/0929 (21.12.2020)

Technical Assessment Body: DIBt - Deutsches Institut für Bautechnik

Notified body/ies: NB 2451 - DVS Zert GmbH

6. Declared performance/s:

Mechanical resistance and stability (BWR 1)

Essential characteristic	Performance
Characteristic resistance under tension load (static and quasi-static load)	
- Resistance to steel failure of anchors, connection and channel lips	See Annex C1
- Resistance to steel failure of channel bolt	See Annex C9
- Resistance to steel failure by exceeding the bending strength of the channel	See Annex B5 and C2
- Maximum installation torque	See Annex B5
- Resistance to pull out failure of the anchor and to concrete cone failure	See Annex C3 and C4
- Minimum edge distance, spacing and member thickness	See Annex B3
- Characteristic edge distance and spacing to avoid splitting of concrete under load	See Annex C3 and C4
- Resistance to blow-out failure – bearing area of anchor head	See Annex A4

Characteristic resistance under shear load (static and quasi-static load)	
- Resistance to steel failure of channel bolt	See Annex C9 and C10
- Resistance to steel failure of channel lips, connection an danchor (shear load perpendicular to longitudinal axis of the channel)	See Annex C5 and C6
- Resistance to steel failure of channel lips, connection an danchor (shear load in direction of longitudinal axis of the channel)	See Annex C5 and C6
- Resistance to concrete failure	See Annex C7
Characteristic resistance of anchor channel under combined tension and shear (static and quasi-static load)	See Annex C8
Characteristic fatigue resistance under cyclic fatigue tension load	See Annex C12 and C13
Displacements (static and quasi-static load)	See Annex C5 and C7 to C8
Durability	See Annex B1

Safety in case of fire (BWR 2)

Essential characteristic	Performance
Reaction to fire	Class A1
Resistance to fire	See Annex C11

The performance of the product identified above is in conformity with the set of declared performance/s. This declaration of performance is issued, in accordance with Regulation (EU) No 305/2011, under the sole responsibility of the manufacturer identified above.

Signed for and on behalf of the manufacturer by:

Heinz Nieder



General manager
PEC Europe GmbH

Gunnar Wald



Head of Quality
Business Unit Anchor

Duisburg, December 2020

Approval body for construction products
and types of construction

Bautechnisches Prüfamt

An institution established by the Federal and
Laender Governments



European Technical Assessment

ETA-16/0929
of 21 December 2020

English translation prepared by DIBt - Original version in German language

General Part

Technical Assessment Body issuing the
European Technical Assessment:

Deutsches Institut für Bautechnik

Trade name of the construction product

Anchor channels (PEC-TA) with channel bolts (HBC)

Product family
to which the construction product belongs

Anchor channels

Manufacturer

PEC Europe GmbH
Obere Kaiserswerther Straße 56
47249 Duisburg
DEUTSCHLAND

Manufacturing plant

Hilti Werke

This European Technical Assessment
contains

31 pages including 3 annexes which form an integral part
of this assessment

This European Technical Assessment is
issued in accordance with Regulation (EU)
No 305/2011, on the basis of

EAD 330008-03-0601

This version replaces

ETA-16/0929 issued on 19 May 2020

The European Technical Assessment is issued by the Technical Assessment Body in its official language. Translations of this European Technical Assessment in other languages shall fully correspond to the original issued document and shall be identified as such.

Communication of this European Technical Assessment, including transmission by electronic means, shall be in full. However, partial reproduction may only be made with the written consent of the issuing Technical Assessment Body. Any partial reproduction shall be identified as such.

This European Technical Assessment may be withdrawn by the issuing Technical Assessment Body, in particular pursuant to information by the Commission in accordance with Article 25(3) of Regulation (EU) No 305/2011.

Specific Part

1 Technical description of the product

The anchor channels (PEC-TA) with channel bolts (HBC) are a system consisting of C-shaped channel profile of carbon steel or stainless steel and at least two metal anchors non-detachably fixed to the channel back and channel bolts.

The anchor channel is embedded surface-flush in the concrete. Channel bolts (HBC) with appropriate hexagon nuts and washers are fixed to the channel.

The product description is given in Annex A.

2 Specification of the intended use in accordance with the applicable European Assessment Document

The performances given in Section 3 are only valid if the anchor channel is used in compliance with the specifications and conditions given in Annex B.

The verifications and assessment methods on which this European Technical Assessment is based lead to the assumption of a working life of the anchor channel of at least 50 years. The indications given on the working life cannot be interpreted as a guarantee given by the producer, but are to be regarded only as a means for choosing the right products in relation to the expected economically reasonable working life of the works.

3 Performance of the product and references to the methods used for its assessment

3.1 Mechanical resistance and stability (BWR 1)

Essential characteristic	Performance
Characteristic resistance under tension load (static and quasi-static load)	
- Resistance to steel failure of anchors, connection and channel lips	See Annex C1
- Resistance to steel failure of channel bolt	See Annex C9
- Resistance to steel failure by exceeding the bending strength of the channel	See Annex B5 and C2
- Max. installation torque	See Annex B5
- Resistance to pull-out failure of the anchor and to concrete cone failure	See Annex C3 and C4
- Min. edge distance, spacing and member thickness	See Annex B3
- Characteristic edge distance and spacing to avoid splitting of concrete under load	See Annex C3 and C4
- Resistance to blow-out failure – bearing area of anchor head	See Annex A4

<p>Characteristic resistance under shear load (static and quasi-static load)</p> <ul style="list-style-type: none"> - Resistance to steel failure of channel bolt - Resistance to steel failure of channel lips, connection and anchor (shear load perpendicular to longitudinal axis of channel) - Resistance to steel failure of channel lips, anchor and connection (shear load in direction of longitudinal axis of channel) - Resistance to concrete failure 	<p>See Annex C9 und C10 See Annex C5 und C6 See Annex C5 und C6 See Annex C7</p>
<p>Characteristic resistance under combined tension and shear load (static and quasi-static load)</p>	<p>See Annex C8</p>
<p>Characteristic resistances under cyclic fatigue tension load</p>	<p>See Annex C12 to C13</p>
<p>Displacements (static and quasi-static load)</p>	<p>See Annex C5 and C7 to C8</p>
<p>Durability</p>	<p>See Annex B1</p>

3.2 Safety in case of fire (BWR 2)

Essential characteristic	Performance
Reaction to fire	Class A1
Characteristic resistance to fire	See Annex C11

4 Assessment and verification of constancy of performance (AVCP) system applied, with reference to its legal base

In accordance with EAD No. 330008-03-0601, the applicable European legal act is: [2000/273/EC].

The system to be applied is: 1

5 Technical details necessary for the implementation of the AVCP system, as provided for in the applicable EAD

Technical details necessary for the implementation of the AVCP system are laid down in the control plan deposited with Deutsches Institut für Bautechnik.

Issued in Berlin on 21 December 2020 on Deutsches Institut für Bautechnik

Dipl.-Ing. Beatrix Wittstock
Head of Section

beglaubigt:
Müller

Product and installation condition

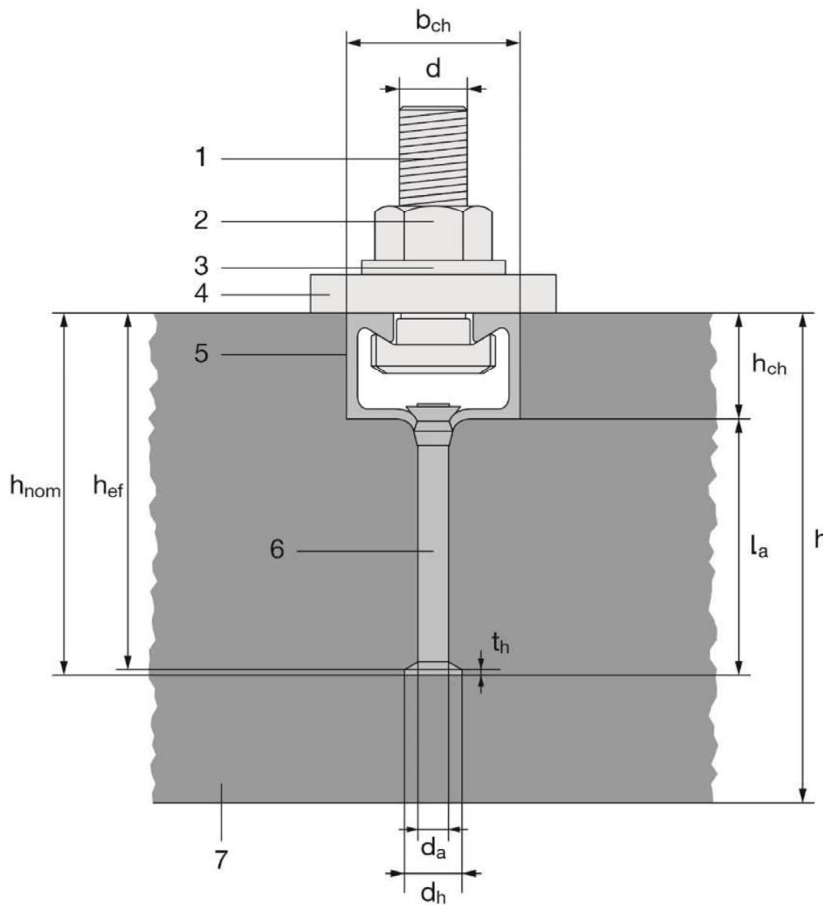

Key

- 1 channel bolt
- 2 hexagonal nut
- 3 washer
- 4 fixture
- 5 channel profile
- 6 anchor
- 7 concrete member

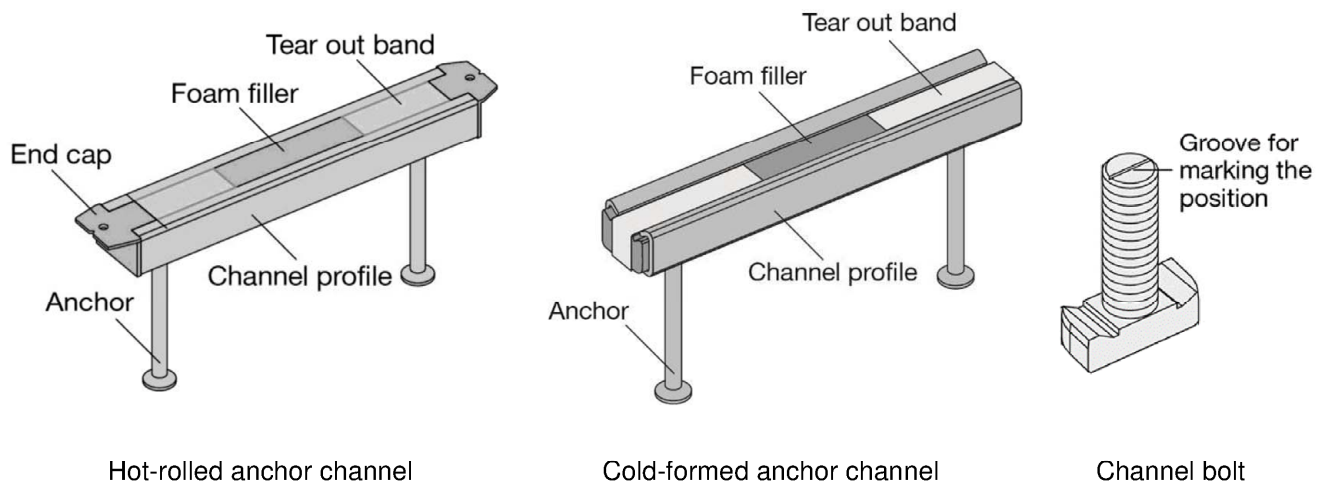

Anchor channels (PEC-TA) with channel bolts (HBC)

Product Description
Installed condition

Annex A1

Anchor channel types

Cold-formed anchor channel

Hot-rolled anchor channel

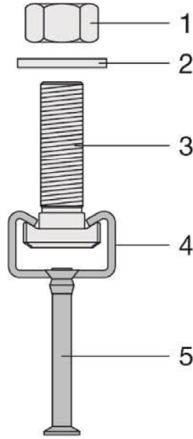

Round anchor

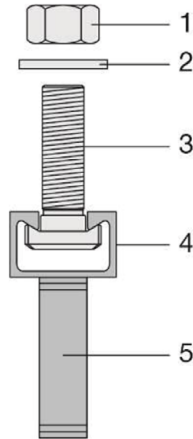

I-anchor

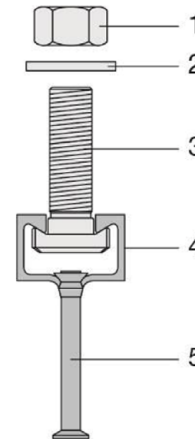

Round anchor

Key

- 1 hexagonal nut
- 2 washer
- 3 channel bolt
- 4 channel profile
- 5 anchor

Marking of the anchor channels:

PEC-TA(-I) XZ (P)

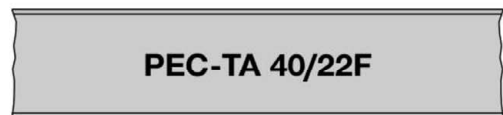

- PEC-TA = Identifying mark of the manufacturer
- P = Additional marking for premium line
- I = Additional marking for I-anchors (no marking in the case of round anchors)
- X = Size of the channel
- Z = Corrosion class / Material
 - F = Hot-dip galvanized
 - A4 = Stainless steel

(e.g. PEC-TA 40/22 F)

- 40/22 = Anchor channel size 40/22
- F = Hot-dip galvanized

Marking of the channel bolt:

HBC-X(-N) YZ

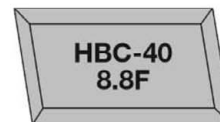

- HBC = Identifying mark of the manufacturer
- X = Channel bolt
- N = Additional marking for notching bolt
- Y = Steel grade (4.6, 8.8, 70)
- Z = Corrosion class / Material
 - F = Hot-dip galvanized
 - R = Stainless steel

(e.g. HBC-40/22 8.8F)

- 40 = Channel bolt in combination with PEC-TA 40/22F
- 8.8 = Steel grade
- F = Hot-dip galvanized

Anchor channels (PEC-TA) with channel bolts (HBC)

Product Description

Anchor channel types and marking

Annex A2

Channel profiles

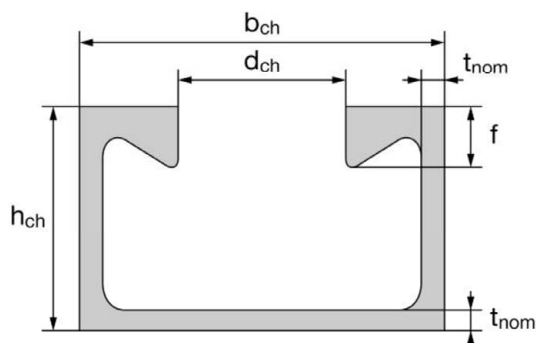

PEC-TA 40/22 (P), PEC-TA 50/30 (P), PEC-TA 52/34

Table 1: Dimensions of hot-rolled channel profile

Anchor channel	b_{ch}	h_{ch}	t_{nom}	d_{ch}	f	I_y
	[mm]					[mm ⁴]
PEC-TA 40/22 (P)	40,1	23,0	2,7	18,0	6,0	21504
PEC-TA 50/30 (P)	49,6	30,0	3,2	22,5	8,1	57781
PEC-TA 52/34	52,5	34,0	4,0	22,5	11,5	97606

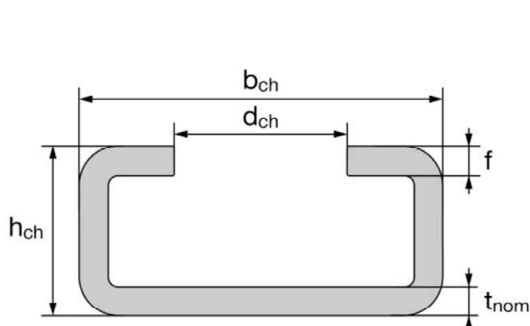

PEC-TA 28/15, PEC-TA 38/17

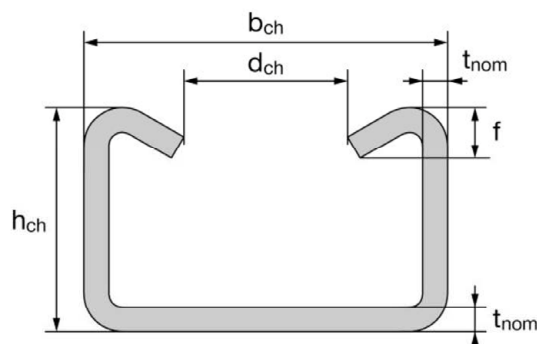

PEC-TA 40/25, PEC-TA 49/30, PEC-TA 54/33

Table 2: Dimensions of cold-formed channel profile

Anchor channel	b_{ch}	h_{ch}	t_{nom}	d_{ch}	f	I_y
	[mm]					[mm ⁴]
PEC-TA 28/15	28,0	15,5	2,3	12,0	2,3	4277
PEC-TA 38/17	38,0	17,3	3,0	18,0	3,0	8224
PEC-TA 40/25	40,0	25,0	2,75	18,0	5,6	20122
PEC-TA 49/30	50,0	30,0	3,25	22,0	7,4	43105
PEC-TA 54/33	53,5	33,0	5,0	21,5	8,0	74706

Anchor channels (PEC-TA) with channel bolts (HBC)

Product Description
Channel profiles (PEC-TA)

Annex A3

Anchors

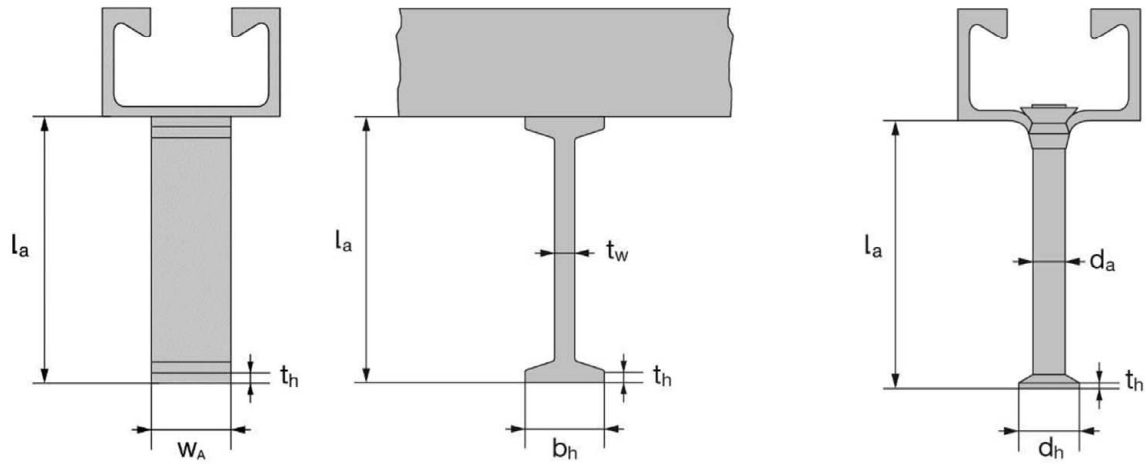

**Table 3: Dimensions of anchor
(welded I-anchor or round anchor)**

Anchor channel	I-anchor						Round anchor				
	min l _a	t _w	b _h	t _h	w _A	A _h	min l _a	d _a	d _h	t _h	A _h
	[mm]						[mm ²]	[mm]			
PEC-TA 28/15	1)						31,0	6,0	12,0	1,3	85
PEC-TA 38/17	1)						60,8	8,0	16,0	2,0	151
PEC-TA 40/25	1)						56,0				
PEC-TA 40/22	62,0	5,0	20,0	5,0	20,0	300	58,0	10,0	21,5	2,2	285
PEC-TA 40/22 P	125,0	6,0	25,0	5,0	20,0	380	70,0				
PEC-TA 49/30	1)						66,0	10,0	20,0	2,2	236
PEC-TA 50/30	69,0	5,0	20,0	5,0	25,0	375					
PEC-TA 50/30 P	125,0	6,0	25,0	5,0	25,0	475	78,0	11,0	26,0	2,5	436
PEC-TA 54/33	1)						124,5	11,0	24,3	2,5	369
PEC-TA 52/34	125,0	6,0	25,0	5,0	40,0	760					

1) Product not available

Anchor channels (PEC-TA) with channel bolts (HBC)

Product Description
Anchors

Annex A4

Channel bolts

Table 4: Dimensions of channel bolt

Appropriate anchor channel	Channel bolt	Dimensions			
		b ₁	b ₂	k	d
		[mm]			
PEC-TA 28/15	HBC-28/15	10,1	22,2	5,0	8
		11,0		6,0	12
PEC-TA 38/17	HBC-38/17	13,0	30,5	6,0	10
		16,0		7,0	16
PEC-TA 40/22 (P) PEC-TA 40/25	HBC-40/22	14,0	33,0	10,5	10
		17,0		11,5	16
PEC-TA 40/22 P	HBC-40/22-N	17,0	33,0	11,5	16
PEC-TA 49/30 PEC-TA 50/30 (P) PEC-TA 52/34 PEC-TA 54/33	HBC-50/30	17,0	42,0	14,5	12
		21,0		15,5	20
PEC-TA 50/30 P PEC-TA 52/34	HBC-50/30-N	21,0	42,0	15,5	16
					20

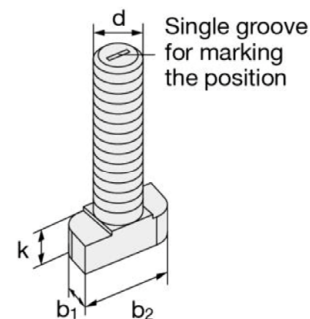

HBC-28/15, HBC-38/17

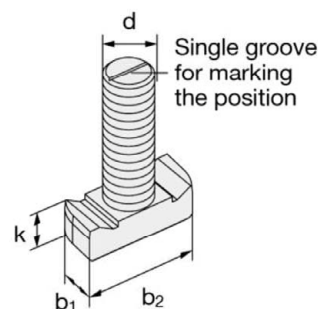

HBC-40/22, HBC-50/30

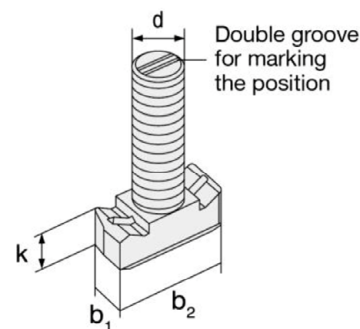

HBC-40/22-N, HBC-50/30-N

Table 5: Steel grade and corrosion class

Channel Bolt	Carbon steel ¹⁾		Stainless steel ¹⁾	
	4.6	8.8	A4-50	A4-70
f _{uk} [N/mm ²]	400	800 / 830 ²⁾	500	700
f _{yk} [N/mm ²]	240	640 / 660 ²⁾	210	450
Corrosion class	G ³⁾ F ⁴⁾		R ⁵⁾	

¹⁾ Material properties according to Annex A6

²⁾ Material properties according to EN ISO 898-1: 2013

³⁾ Electroplated

⁴⁾ Hot-dip galvanized

⁵⁾ Stainless steel

Anchor channels (PEC-TA) with channel bolts (HBC)

Product Description
Channel bolts (HBC)

Annex A5

Table 6: Materials

Component	Carbon steel			Stainless steel
	Mechanical properties	Coating		Mechanical properties
1	2a	2b	2c	3
Channel Profile	1.0038, 1.0044, 1.0045 according to EN 10025: 2005 1.0976, 1.0979 according to EN 10149: 2013	Hot dip galvanized $\geq 50 \mu\text{m}$ according to EN ISO 10684: 2004/AC: 2009		1.4362, 1.4401 1.4404, 1.4571, 1.4578 according to EN 10088: 2005
Anchor	1.0038, 1.0213, 1.0214 according to EN 10025: 2005 1.5523, 1.5535 according to EN 10263: 2002-02	-	Hot dip galvanized $\geq 50 \mu\text{m}$ according to EN ISO 10684: 2004/AC: 2009	1.4362, 1.4401 1.4404, 1.4571, 1.4578 according to EN 10088: 2005 ³⁾
Channel bolt	Steel grade 4.6 and 8.8 according to EN ISO 898-1: 2013	Electroplated according to EN ISO 4042: 1999	Hot dip galvanized $\geq 50 \mu\text{m}$ according to EN ISO 10684: 2004/AC: 2009	Grade 50 or 70 according to EN ISO 3506: 2009
Plain washer ¹⁾ according to ISO 7089: 2000 and ISO 7093-1: 2000	Hardness class A $\geq 200 \text{ HV}$	Electroplated according to EN ISO 4042: 1999	Hot dip galvanized $\geq 50 \mu\text{m}$ according to EN ISO 10684: 2004/AC: 2009	1.4401, 1.4404 1.4571, 1.4578 according to EN 10088: 2005
Hexagonal nut according to ISO 4032: 2012 or DIN 934: 1987-10 ²⁾	Property class 5 or 8 according to EN ISO 898-2: 2012	Electroplated according to EN ISO 4042: 1999	Hot dip galvanized $\geq 50 \mu\text{m}$ according to EN ISO 10684: 2004/AC: 2009	Property class 50, 70 or 80 according to EN ISO 3506: 2009

¹⁾ In scope of delivery only for notched bolts

²⁾ Hexagonal nuts according to DIN 934: 1987-10 for channel bolts made from carbon steel (4.6) and stainless steel

³⁾ Anchors made of carbon steel according column 2a may also be used if they are welded and their concrete cover is more than 50mm and the tempering colors are removed

Anchor channels (PEC-TA) with channel bolts (HBC)

Product Description
Materials

Annex A6

Specifications of intended use

Anchor channels and channel bolts subject to:

- Static and quasi-static loads in tension, shear perpendicular to the longitudinal axis of the channel and shear in the direction of the longitudinal axis.
- Fire exposure: only for concrete class C20/25 to C50/60.
- Fatigue cycling tension loads.

Base materials:

- Reinforced or unreinforced normal weight concrete according to EN 206-1: 2000.
- Strength classes C12/15 to C90/105 according to EN 206-1: 2000.
- Cracked or uncracked concrete.

Use conditions (Environmental conditions):

- Structures subject to dry internal conditions (anchor channels and channel bolts according to Annex A6, Table 6, column 2 and 3).
- Structures subject to internal conditions with usual humidity (e.g. kitchen, bath and laundry in residential buildings, exceptional permanent damp conditions and application under water) (anchor channels and channel bolts according to Annex A6, Table 6, column 2c and 3).
- According to EN 1993-1-4: 2006 + A2: 2015 relating to corrosion resistance class CRC III (anchor channels, channel bolts according to Annex A6, Table 6, column 3)

Design:

- Anchor channels are designed under the responsibility of an engineer experienced in anchorages and concrete work.
- Verifiable calculation notes and drawings are prepared taking account of the loads to be anchored. The position of the anchor channel and channel bolts are indicated on the design drawings (e.g. position of the anchor channel relative to the reinforcement or to supports).
- For static and quasi-static loading as well as fire exposure the anchor channels are designed in accordance with EOTA TR 047 "Calculation Method for the Performance of Anchor Channels", March 2018 or EN 1992-4: 2018.
- For fatigue loading the anchor channels are designed in accordance with EOTA TR 050 "Calculation Method for the Performance of Anchor Channels under Fatigue Loading", November 2015.
- The characteristic resistances are calculated with the minimum effective embedment depth.

Anchor channels (PEC-TA) with channel bolts (HBC)

Intended Use
Specifications

Annex B1

Installation:

- The installation of anchor channels is carried out by appropriately qualified personnel under the supervision of the person responsible for the technical matters on site.
- Use of the anchor channels only as supplied by the manufacturer - without any manipulations, repositioning or exchanging of channel components.
- Cutting of anchor channels is allowed only if pieces according to Annex B3, Table 7 and Table 8 are generated including end spacing and minimum channel length and in case of hot-dip galvanised anchor channels only to be used in dry internal conditions.
- Installation in accordance with the manufacturer's specifications given in Annexes B6, B7 and B8
- The anchor channels are fixed on the formwork, reinforcement or auxiliary construction such that no movement of the channels will occur during the time of laying the reinforcement and of placing and compacting the concrete.
- The concrete around the head of the anchors are properly compacted. The channels are protected from penetration of concrete into the internal space of the channels.
- Washer may be chosen according to Annex A6 and provided separately by the user.
- Orientating the channel bolt (groove according to Annex B7 and Annex B8) rectangular to the channel axis.
- The required installation torques given in Annex B5 must be applied and must not be exceeded.

Anchor channels (PEC-TA) with channel bolts (HBC)

Intended Use
Specifications

Annex B2

Table 7: Installation parameters for hot-rolled anchor channel

Anchor channel		PEC-TA 40/22	PEC-TA 40/22 P	PEC-TA 50/30	PEC-TA 50/30 P	PEC-TA 52/34
Minimum effective embedment depth	$h_{ef,min}$	79	91	94	106	155
Minimum spacing	s_{min}	100	50	100	50 ¹⁾	100
Maximum spacing	s_{max}	250				
End spacing	x	25 ²⁾				35 ³⁾
Minimum channel length	l_{min}	150	100	150	100	170 ⁴⁾
Minimum edge distance	c_{min}	50		75		75
Minimum thickness of concrete member	h_{min}	100	100	105	120	165

¹⁾ $s_{min} = 100$ mm when used in combination with notched bolts

²⁾ The end spacing may be increased from 25 mm to 35 mm

³⁾ $x = 25$ mm for welded I-anchors

⁴⁾ $l_{min} = 150$ mm for welded I-anchors

Table 8: Installation parameters for cold-formed anchor channel

Anchor channel		PEC-TA 28/15	PEC-TA 38/17	PEC-TA 40/25	PEC-TA 49/30	PEC-TA 54/33
Minimum effective embedment depth	$h_{ef,min}$	45	76	79	94	155
Minimum spacing	s_{min}	50	100			
Maximum spacing	s_{max}	200		250		
End spacing	x	25 ¹⁾				
Minimum channel length	l_{min}	100	150			
Minimum edge distance	c_{min}	40	50		75	100
Minimum thickness of concrete member	h_{min}	70	100		120	180

¹⁾ The end spacing may be increased from 25 mm to 35 mm

Anchor channels (PEC-TA) with channel bolts (HBC)

Intended Use
Installation parameters for anchor channels (PEC-TA)

Annex B3

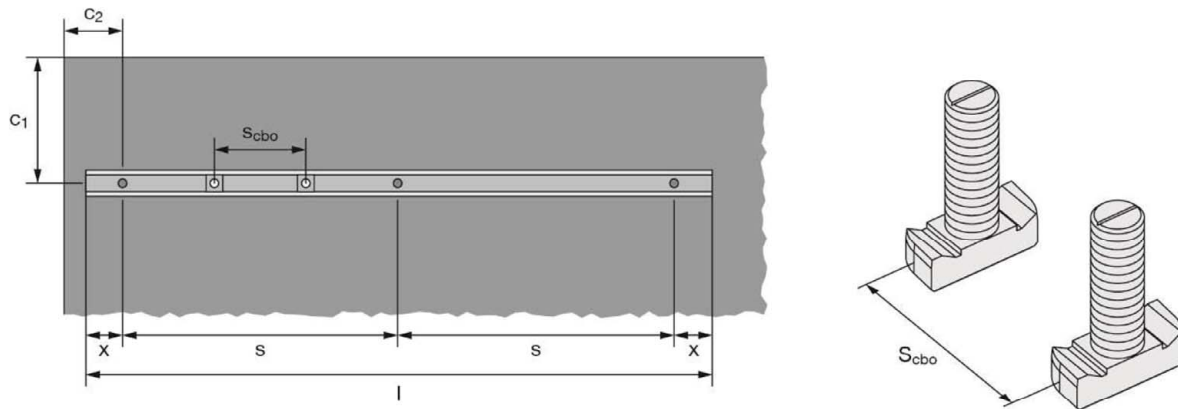

Table 9: Minimum spacing for channel bolts

Channel bolt			M8	M10	M12	M16	M20
Minimum spacing between channel bolts	$S_{cbo,min}$	[mm]	40	50	60	80	100

S_{cbo} = spacing between channel bolts

Anchor channels (PEC-TA) with channel bolts (HBC)

Intended Use
Installation parameters for anchor channels (PEC-TA)

Annex B4

Table 10: Required installation torque T_{inst}

Channel bolt		$T_{inst}^{1)}$ [Nm]					
		General: $T_{inst,g}$	Steel - steel contact: $T_{inst,s}$				
		4.6, 8.8, A4-50, A4-70	4.6	8.8	A4-50	A4-70	
HBC-28/15	M8	7	2)	20	7	15	
	M10	10		40		30	
	M12	13		60		50	
HBC-38/17	M10	15	13	2)	2)	22	
	M12	25	2)	45		50	
	M16	40		100		90	
HBC-40/22	M10	15	13	2)	2)	22	
	M12	25	2)	45		50	
	M16	30		100		90	
HBC-40/22-N	M16	160	2)	160	2)	2)	
HBC-50/30	M12	25		2)		45	50
	M16	55				100	130
	M20	55	360		250		
HBC-50/30-N	M16	185	2)	185	2)	2)	
	M20	320		320			

1) T_{inst} must not be exceeded

2) Product not available

General: The fixture is in contact with the channel profile and the concrete surface

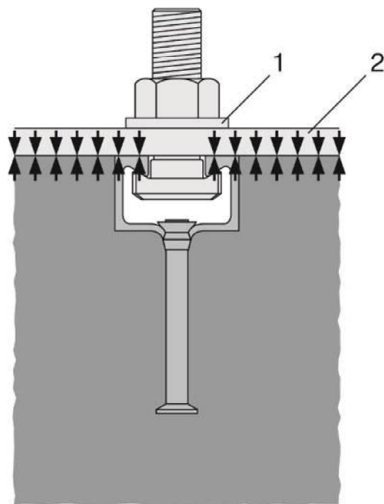

Steel-steel contact: Fixture is not in contact with the concrete surface. The fixture is fastened to the anchor channel by suitable steel part (e.g. washer)

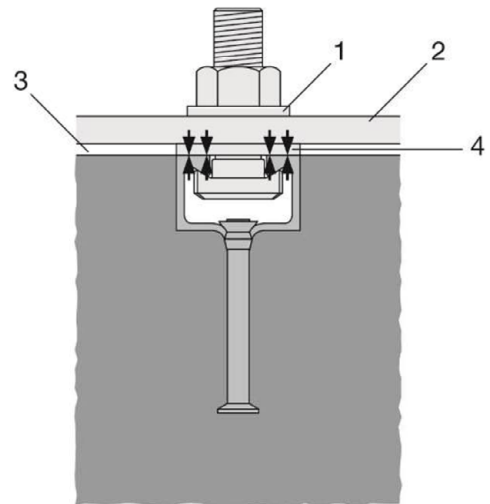

Key

- 1 washer
- 2 fixture
- 3 gap
- 4 suitable steel part

Anchor channels (PEC-TA) with channel bolts (HBC)

Intended Use
Installation parameters for channel bolts (HBC)

Annex B5

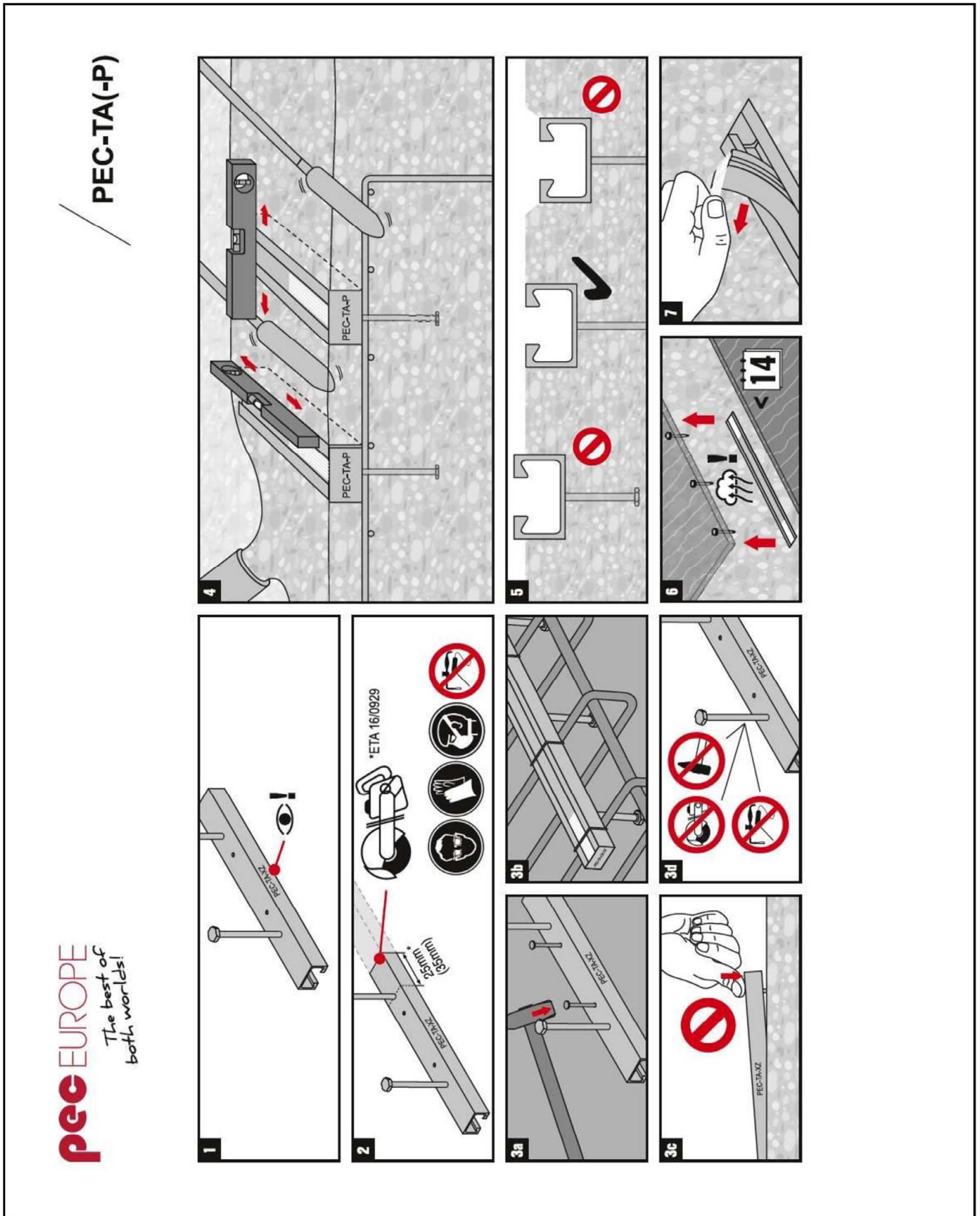

Anchor channels (PEC-TA) with channel bolts (HBC)

Intended Use
Installation instructions for anchor channels (PEC-TA)

Annex B6

pec EUROPE
The best of
both worlds!

HBC

1

HBC-28	PEC-TA-28/15
HBC-38	PEC-TA-38/17
HBC-40	PEC-TA-40/22-P, PEC-TA-40/22, PEC-TA-40/25
HBC-50	PEC-TA-49/30, PEC-TA-50/30-P, PEC-TA-50/30
	PEC-TA-52/34, PEC-TA-54/33

2

3

4

5

6

7

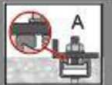
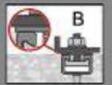
Channel bolt		T _{inst} (Nm)				
						
			4,6, 8,8, A4-50 A4-70	4,6	8,8	A4-50
28/15	M8	7		20	7	15
	M10	10	-	40		30
	M12	13		60		50
38/17	M10	15	13	15	-	22
	M12	25		45		50
	M16	40		100		90
40/22	M10	15	13	15	-	22
	M12	25		45		50
	M16	30		100		90
50/30	M12	25		45	-	50
	M16	55		100		130
	M20	55		360		250

Anchor channels (PEC-TA) with channel bolts (HBC)

Intended Use
Installation instructions for channel bolts (HBC)

Annex B7

pec EUROPE
The best of
both worlds!

HBC-N

Version - 11.2020

1 		

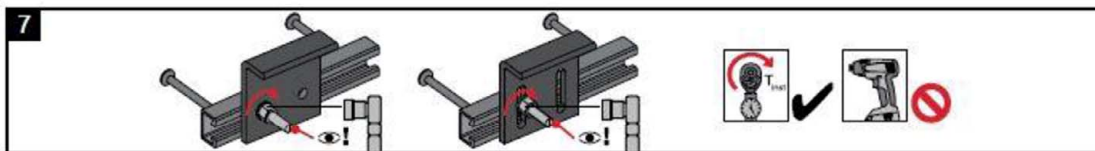
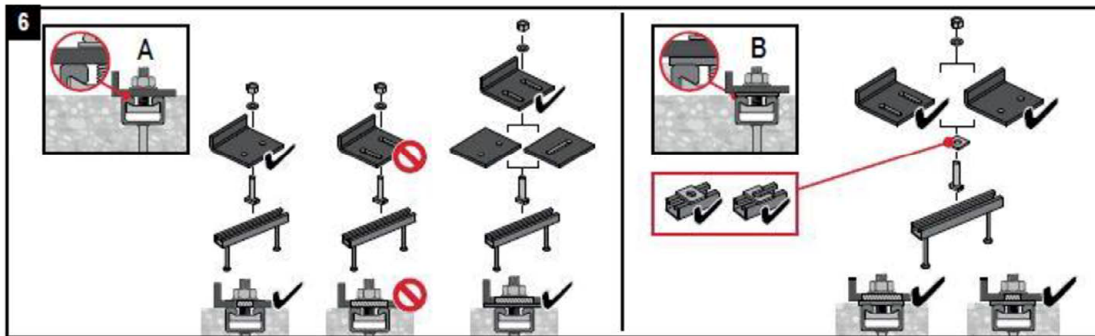
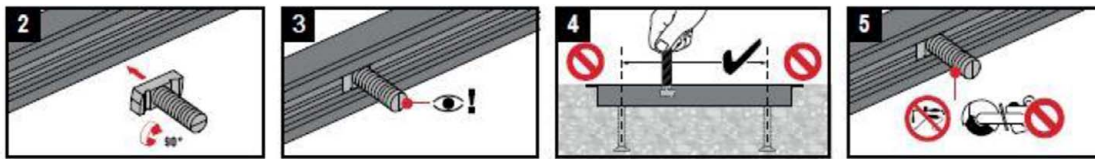

Anchor Channel	Channel Bolt	T_{Inst} [Nm]	
PEC-TA 40/22-P	HBC-40/22-N M16	8.8	8.8
PEC-TA 40/22		160	160
PEC-TA 50/30-P	HBC-50/30-N M16	60	160
PEC-TA 50/30		185	185
PEC-TA 52/34	HBC-50/30-N M20	320	320
PEC-TA 50/30-P			
PEC-TA 50/30			
PEC-TA 52/34			

Anchor channels (PEC-TA) with channel bolts (HBC)

Intended Use
Installation instructions for channel bolts (HBC)

Annex B8

Table 11: Characteristic resistances under tension load – steel failure of hot-rolled anchor channels

Anchor channel			PEC-TA 40/22	PEC-TA 40/22 P	PEC- TA50/30	PEC-TA 50/30 P	PEC-TA 52/34
Steel failure: Anchor							
Characteristic resistance	$N_{Rk,s,a}$	[kN]	20,0	40,0	31,0	57,0	55,0
Partial factor	γ_{Ms} ¹⁾	[-]	1,8				
Steel failure: Connection between anchor and channel							
Characteristic resistance	$N_{Rk,s,c}$	[kN]	20,0	39,6	31,0	50,6	55
Partial factor	$\gamma_{Ms,ca}$ ¹⁾	[-]	1,8				
Steel failure: Local flexure of channel lips							
Characteristic spacing of the channel bolts for $N_{Rk,s,l}$	$s_{l,N}$	[mm]	79	79	98	98	105
Characteristic resistance	$N^0_{Rk,s,l}$	[kN]	47,9	47,9	50,5	50,5	65,0
Partial factor	$\gamma_{Ms,l}$ ¹⁾	[-]	1,8				

¹⁾ In absence of other national regulations

Table 12: Characteristic resistances under tension load – steel failure of cold-formed anchor channels

Anchor channel			PEC-TA 28/15	PEC-TA 38/17	PEC-TA 40/25	PEC-TA 49/30	PEC-TA 54/33
Steel failure: Anchor							
Characteristic resistance	$N_{Rk,s,a}$	[kN]	9,0	18,0	20,0	31,0	55,0
Partial factor	γ_{Ms} ¹⁾	[-]	1,8				
Steel failure: Connection between anchor and channel							
Characteristic resistance	$N_{Rk,s,c}$	[kN]	9,0	18,0	20,0	31,0	55,0
Partial factor	$\gamma_{Ms,ca}$ ¹⁾	[-]	1,8				
Steel failure: Local flexure of channel lips							
Characteristic spacing of the channel bolts for $N_{Rk,s,l}$	$s_{l,N}$	[mm]	56	76	80	100	107
Characteristic resistance	$N^0_{Rk,s,l}$	[kN]	9,0	18,0	20,0	31,0	55,0
Partial factor	$\gamma_{Ms,l}$ ¹⁾	[-]	1,8				

¹⁾ In absence of other national regulations

Anchor channels (PEC-TA) with channel bolts (HBC)

Performance Data

Characteristic resistances of anchor channels under tension load

Annex C1

Table 13: Characteristic flexural resistance of hot-rolled anchor channels under tension load

Anchor channel			PEC-TA 40/22	PEC-TA-P 40/22	PEC-TA 50/30	PEC-TA-P 50/30	PEC-TA 52/34
Steel failure: Flexure of channel							
Characteristic flexural resistance of channel	$M_{Rk,s,flex}$	[Nm]	1013	1704	2084	3448	3435
Partial factor	$\gamma_{Ms,flex}^{1)}$	[-]	1,15				

¹⁾ In absence of other national regulations

Table 14: Characteristic flexural resistance of cold-formed anchor channels under tension load

Anchor channel			PEC-TA 28/15	PEC-TA 38/17	PEC-TA 40/25	PEC-TA 49/30	PEC-TA 54/33
Steel failure: Flexure of channel							
Characteristic flexural resistance of channel	carbon steel	$M_{Rk,s,flex}$	316	538	979	1669	2929
	stainless steel			527		1702	2832
Partial factor	$\gamma_{Ms,flex}^{1)}$	[-]	1,15				

¹⁾ In absence of other national regulations

Anchor channels (PEC-TA) with channel bolts (HBC)

Performance Data

Characteristic resistances of anchor channels under tension load

Annex C2

Table 15: Characteristic resistances under tension load – concrete failure of hot-rolled anchor channels

Anchor channel			PEC-TA 40/22		PEC-TA 40/22 P		PEC-TA 50/30		PEC-TA 50/30 P		PEC-TA 52/34	
Type of anchor			I	R	I	R	I	R	I	R	I	R
Concrete failure: Pull-out												
Characteristic resistance in cracked concrete C12/15	N _{Rk,p}	[kN]	27,0	13,6	34,2	25,6	33,8	21,2	42,8	39,2	68,4	33,2
Characteristic resistance in uncracked concrete C12/15			37,8	19,0	47,9	35,8	47,3	29,7	59,9	54,9	95,8	46,5
Factor for N _{Rk,p} N _{Rk,p} = N _{Rk,p (C12/15)} · ψ _c	C16/20	ψ _c [-]	1,33									
	C20/25		1,67									
	C25/30		2,08									
	C30/37		2,50									
	C35/45		2,92									
	C40/50		3,33									
	C45/55		3,75									
	C50/60		4,17									
	C55/67		4,58									
≥ C60/75	5,00											
Partial factor	γ _{Mp} = γ _{Mc} ²⁾	[-]	1,5									
Concrete failure: Concrete cone												
Product factor k ₁	cracked concrete	k _{cr,N}	[-]	7,9	8,0	8,1	8,2	8,7				
	uncracked concrete	k _{ucr,N}	[-]	11,2	11,5	11,6	11,7	12,4				
Partial factor	γ _{Mc} ²⁾	[-]	1,5									
Concrete failure: Splitting												
Characteristic edge distance	c _{cr,sp}	[mm]	237	273	282	318	465					
Characteristic spacing	s _{cr,sp}	[mm]	474	546	564	636	930					
Partial factor	γ _{Msp} = γ _{Mc} ²⁾	[-]	1,5									

1) Product not available

2) In absence of other national regulations

Anchor channels (PEC-TA) with channel bolts (HBC)

Performance Data

Characteristic resistances of anchor channels under tension load

Annex C3

Table 16: Characteristic resistances under tension load – concrete failure of cold-formed anchor channels

Anchor channel			PEC-TA 28/15	PEC-TA 38/17	PEC-TA 40/25	PEC-TA 49/30	PEC-TA 54/33	
Type of anchor			R	R	R	R	R	
Concrete failure: Pull-out								
Characteristic resistance in cracked concrete C12/15	$N_{Rk,p}$	[kN]	7,6	13,6	13,6	21,2	33,2	
Characteristic resistance in uncracked concrete C12/15			10,7	19,0	19,0	29,7	46,5	
Factor for $N_{Rk,p}$ $N_{Rk,p} = N_{Rk,p(C12/15)} \cdot \psi_c$	C16/20	ψ_c [-]	1,33					
	C20/25		1,67					
	C25/30		2,08					
	C30/37		2,50					
	C35/45		2,92					
	C40/50		3,33					
	C45/55		3,75					
	C50/60		4,17					
	C55/67		4,58					
	$\geq C60/75$		5,00					
Partial factor	$\gamma_{Mp} = \gamma_{Mc}^{1)}$	[-]	1,5					
Concrete failure: Concrete cone								
Product factor k_1	cracked concrete	$k_{cr,N}$	[-]	7,2	7,8	7,9	8,1	8,7
	uncracked concrete	$k_{ucr,N}$	[-]	10,3	11,2	11,2	11,6	12,4
Partial factor	$\gamma_{Mc}^{1)}$	[-]	1,5					
Concrete failure: Splitting								
Characteristic edge distance	$c_{cr,sp}$	[mm]	135	228	237	282	465	
Characteristic spacing	$s_{cr,sp}$	[mm]	270	456	474	564	930	
Partial factor	$\gamma_{Msp} = \gamma_{Mc}^{1)}$	[-]	1,5					

¹⁾ In absence of other national regulations

Anchor channels (PEC-TA) with channel bolts (HBC)

Performance Data

Characteristic resistances of anchor channels under tension load

Annex C4

Table 17: Displacements of hot-rolled anchor channels under tension load

Anchor channel			PEC-TA 40/22	PEC-TA 40/22 P	PEC-TA 50/30	PEC-TA 50/30 P	PEC-TA 52/34
Tension load	N	[kN]	13,9	15,3	14,3	25,8	25,8
Short-term displacement ¹⁾	δ_{N0}	[mm]	2,3	1,1	2,2	1,4	1,4
Long-term displacement ¹⁾	$\delta_{N\infty}$	[mm]	4,6	2,2	4,4	2,8	2,8

¹⁾ Displacements in midspan of the anchor channel, including slip of channel bolt, deformation of channel lips, bending of the channel and slip of the anchor channel in concrete

Table 18: Displacements of cold-formed anchor channels under tension load

Anchor channel			PEC-TA 28/15	PEC-TA 38/17	PEC-TA 40/25	PEC-TA 49/30	PEC-TA 54/33
Tension load	N	[kN]	3,6	7,1	7,9	12,3	21,8
Short-term displacement ¹⁾	δ_{N0}	[mm]	0,6	1,3	1,4	1,4	1,6
Long-term displacement ¹⁾	$\delta_{N\infty}$	[mm]	1,2	2,6	2,8	2,8	3,2

¹⁾ Displacements in midspan of the anchor channel, including slip of channel bolt, deformation of channel lips, bending of the channel and slip of the anchor channel in concrete

Table 19: Characteristic resistances under shear load – steel failure of hot-rolled anchor channel

Anchor channel			PEC-TA 40/22	PEC-TA 40/22 P	PEC-TA 50/30	PEC-TA 50/30 P	PEC-TA 52/34
Steel failure: Anchor							
Characteristic resistance	$V_{Rk,s,a,y}$	[kN]	26,0	58,1	40,3	100,0	121,5
Characteristic resistance	$V_{Rk,s,a,x}$	[kN]	²⁾	24,0	²⁾	34,2	33,1
Partial factor	γ_{Ms} ¹⁾	[-]	1,5				
Steel failure: Connection between anchor and channel							
Characteristic resistance	$V_{Rk,s,c,y}$	[kN]	26,0	58,1	40,3	100,0	121,5
Characteristic resistance	$V_{Rk,s,c,x}$	[kN]	²⁾	23,8	²⁾	30,4	28,1
Partial factor	$\gamma_{Ms,ca}$ ¹⁾	[-]	1,8				
Steel failure: Local flexure of channel lips under shear load perpendicular to the longitudinal axis of the channel							
Characteristic spacing of channel bolts for $V_{Rk,s,l}$	$s_{l,v}$	[mm]	80	80	99	99	105
Characteristic resistance	$V^0_{Rk,s,l,y}$	[kN]	55,0	55,0	91,7	91,7	71,5
Partial factor	$\gamma_{Ms,l}$ ¹⁾	[-]	1,8				

¹⁾ In absence of other national regulations

²⁾ No performance assessed

Anchor channels (PEC-TA) with channel bolts (HBC)

Performance Data

Displacements under tension load.
Characteristic resistances of anchor channels under shear load

Annex C5

Table 20: Characteristic resistances under shear load in direction of the longitudinal axis of the channel – steel failure of hot-rolled anchor channel

Anchor channel			PEC-TA 40/22	PEC-TA 40/22 P	PEC-TA 50/30	PEC-TA 50/30 P	PEC-TA 52/34	
Steel failure: Connection between channel lips and channel bolt								
Characteristic resistance	$V_{Rk,s,l,x}$ [kN]	HBC-40/22-N M16 8.8F	2)	2)	2)	12,5	1)	
		HBC-50/30-N M16 8.8F					8,3	8,3
		HBC-50/30-N M20 8.8F					8,3	8,3
Installation factor	γ_{inst}	[-]		1,4			1,0	

1) Product not available

2) No performance assessed

Table 21: Characteristic resistances under shear load – steel failure of cold-formed anchor channel

Anchor channel			PEC-TA 28/15	PEC-TA 38/17	PEC-TA 40/25	PEC-TA 49/30	PEC-TA 54/33
Steel failure: Anchor							
Characteristic resistance	$V_{Rk,s,a,y}$	[kN]	9,0	18,0	20,0	31,0	55,0
Partial factor	γ_{Ms} 1)	[-]	1,5				
Steel failure: Connection between anchor and channel							
Characteristic resistance	$V_{Rk,s,c,y}$	[kN]	9,0	18,0	20,0	31,0	55,0
Partial factor	$\gamma_{Ms,ca}$ 1)	[-]	1,8				
Steel failure: Local flexure of channel lips under shear load perpendicular to the longitudinal axis of the channel							
Characteristic spacing of channel bolts for $V_{Rk,s,l}$	$s_{l,v}$	[mm]	56	76	80	100	107
Characteristic resistance	$V^0_{Rk,s,l,y}$	[kN]	9,0	18,0	20,0	31,0	55,0
Partial factor	$\gamma_{Ms,l}$ 1)	[-]	1,8				

1) In absence of other national regulations

Anchor channels (PEC-TA) with channel bolts (HBC)

Performance Data

Characteristic resistances of anchor channels under shear load

Annex C6

Table 22: Characteristic resistances under shear load – concrete failure of hot-rolled anchor channel

Anchor channel			PEC-TA 40/22	PEC-TA-P 40/22	PEC-TA 50/30	PEC-TA-P 50/30	PEC-TA 52/34
Concrete failure: Pry out							
Product factor	k_8	[-]	2,0				
Partial factor	$\gamma_{Mc}^{1)}$	[-]	1,5				
Concrete failure: Concrete edge							
Product factor k_{12}	cracked concrete	$k_{cr,V}$	[-]	7,5			
	uncracked concrete	$k_{ucr,V}$	[-]	10,5			
Partial factor	$\gamma_{Mc}^{1)}$	[-]	1,5				

¹⁾ In absence of other national regulations

Table 23: Characteristic resistances under shear load – concrete failure of cold-formed anchor channel

Anchor channel			PEC-TA 28/15	PEC-TA 38/17	PEC-TA 40/25	PEC-TA 49/30	PEC-TA 54/33
Concrete failure: Pry out							
Product factor	k_8	[-]	1,0	2,0			
Partial factor	$\gamma_{Mc}^{1)}$	[-]	1,5				
Concrete failure: Concrete edge							
Product factor k_{12}	cracked concrete	$k_{cr,V}$	[-]	6,9	6,9	7,5	
	uncracked concrete	$k_{ucr,V}$	[-]	9,6	9,6	10,5	
Partial factor	$\gamma_{Mc}^{1)}$	[-]	1,5				

¹⁾ In absence of other national regulations

Table 24: Displacements under shear load of hot-rolled anchor channel

Anchor channel			PEC-TA 40/22	PEC-TA 40/22 P	PEC-TA 50/30	PEC-TA 50/30 P	PEC-TA 52/34
Shear load	V_y	[kN]	10,3	29,0	16,0	39,7	28,4
Short-term displacement ¹⁾	$\delta_{V0,y}$	[mm]	2,1	2,0	2,6	2,7	3,7
Long-term displacement ¹⁾	$\delta_{V\infty,y}$	[mm]	3,1	3,5	3,9	4,0	5,5
Shear load	V_x	[kN]	²⁾	5,2	²⁾	3,3	7,9
Short-term displacement ¹⁾	$\delta_{V0,x}$	[mm]	²⁾	0,1	²⁾	0,1	1,4
Long-term displacement ¹⁾	$\delta_{V\infty,x}$	[mm]	²⁾	0,2	²⁾	0,2	2,0

¹⁾ Displacements in midspan of the anchor channel, including slip of channel bolt, deformation of channel lips and slip of the anchor channel in concrete

²⁾ No performance assessed

Anchor channels (PEC-TA) with channel bolts (HBC)

Performance Data

Characteristic resistances and displacements of anchor channels under shear load

Annex C7

Table 25: Displacements under shear load of cold-formed anchor channel

Anchor channel			PEC-TA 28/15	PEC-TA 38/17	PEC-TA 40/25	PEC-TA 49/30	PEC-TA 54/33
Shear load	V_y	[kN]	3,6	7,1	7,9	12,3	21,8
Short-term displacement ¹⁾	$\delta_{v0,y}$	[mm]	0,6	1,3	1,4	1,4	1,6
Long-term displacement ¹⁾	$\delta_{v\infty,y}$	[mm]	0,9	2,0	2,1	2,1	2,4

¹⁾ Displacements in midspan of the anchor channel, including slip of channel bolt, deformation of channel lips and slip of the anchor channel in concrete

Table 26: Characteristic resistances under combined tension and shear load of hot-rolled anchor channel

Anchor channel			PEC-TA 40/22	PEC-TA-P 40/22	PEC-TA 50/30	PEC-TA-P 50/30	PEC-TA 52/34
Steel failure: Local flexure of channel lips and flexure of channel							
Product factor	k_{13}	[-]	Values according to EN 1992-4:2018, Section 7.4.3.1				
Steel failure: Anchor and connection between anchor and channel							
Product factor	k_{14}	[-]	Values according to EN 1992-4:2018, Section 7.4.3.1				

Table 27: Characteristic resistances under combined tension and shear load of cold-formed anchor channel

Anchor channel			PEC-TA 28/15	PEC-TA 38/17	PEC-TA 40/25	PEC-TA 49/30	PEC-TA 54/33
Steel failure: Local flexure of channel lips and flexure of channel							
Product factor	k_{13}	[-]	Values according to EN 1992-4:2018, Section 7.4.3.1				
Steel failure: Anchor and connection between anchor and channel							
Product factor	k_{14}	[-]	Values according to EN 1992-4:2018, Section 7.4.3.1				

Anchor channels (PEC-TA) with channel bolts (HBC)

Performance Data

Displacements under shear load
Characteristic resistances under combined tension and shear load

Annex C8

Table 28: Characteristic resistances under tension and shear load – steel failure of channel bolts

Channel bolt				M8	M10	M12	M16	M20	
Steel failure									
Characteristic resistance (tension load)	$N_{Rk,s}$	[kN]	HBC-28/15	4.6	1)				
				8.8	22,4	35,4	44,3	1)	
				A4-50 ²⁾	17,2	1)			
				A4-70 ²⁾	25,6	38,9	51,3	1)	
			HBC-38/17	4.6	1)	23,2	1)		
				8.8		35,4	55,8	1)	
				A4-70 ²⁾		20,5	47,2	53,0	
			HBC-40/22	4.6	1)	23,2	1)		
				8.8		67,4	125,6	1)	
				A4-70 ²⁾		20,5	59,0	91,0	
			HBC-40/22-N	8.8	1)		125,6	1)	
			HBC-50/30	4.6	1)				
				8.8	1)	67,4	125,6	147,1	
				A4-70 ²⁾		59,0	109,9	121,2	
				HBC-50/30-N	8.8	1)		125,6	186,6
			Partial factor	$\gamma_{Ms}^{3)}$	[-]	HBC-28/15	4.6	2,00	
HBC-38/17	8.8	1,50							
HBC-40/22	A4-50 ²⁾	2,86							
HBC-50/30	A4-70 ²⁾	1,87							
Characteristic resistance (shear load)	$V_{Rk,s}$	[kN]	HBC-28/15	4.6	1)				
				8.8	14,6	23,2	33,7	1)	
				A4-50 ²⁾	11,0	1)			
				A4-70	15,4	24,4	35,4	1)	
			HBC-38/17	4.6	1)	13,9	1)		
				8.8		33,7	62,8	1)	
				A4-70 ²⁾		24,4	35,4	65,9	
			HBC-40/22	4.6	1)	13,9	1)		
				8.8		23,2	33,7	62,8	1)
			HBC-40/22-N	A4-70 ²⁾	24,4	35,4	65,9	1)	
				8.8	1)		62,8	1)	
			HBC-50/30	4.6	1)				
8.8	1)	33,7		62,8	101,7				
A4-70 ²⁾		35,4		65,9	102,9				
HBC-50/30-N	8.8	1)		62,8	101,7				
Partial factor	$\gamma_{Ms}^{3)}$	[-]	HBC-28/15	4.6	1,67				
			HBC-38/17	8.8	1,25				
			HBC-40/22	A4-50 ²⁾	2,38				
			HBC-50/30	A4-70	1,56				

1) Product not available

2) Materials according to Table 6, Annex A6

3) In absence of other national regulations

Anchor channels (PEC-TA) with channel bolts (HBC)

Performance Data

Characteristic resistance of channel bolts under tension and shear load

Annex C9

Table 29: Characteristic resistances under shear load with lever arm – steel failure of channel bolts

Channel bolt				M8	M10	M12	M16	M20		
Steel failure										
Characteristic flexural resistance	$M^{0}_{Rk,s}{}^{5)}$	[Nm]	HBC-28/15	4,6	4)	29,9 ³⁾	4)			
			HBC-38/17	8,8	30,0	59,8	104,8	266,4	538,7	
			HBC-40/22(-N)	A4-50 ²⁾	18,7	4)				
			HBC-50/30(-N)	A4-70 ²⁾	26,2	52,3	91,7	233,1	454,4	
Partial factor	$\gamma_{Ms}{}^{1)}$	[-]	HBC-28/15	4,6	1,67					
			HBC-38/17	8,8	1,25					
			HBC-40/22(-N)	A4-50 ²⁾	2,38					
			HBC-50/30(-N)	A4-70 ²⁾	1,56					
Internal lever arm	a	[mm]	HBC-28/15	28/15	17,3	18,7	20,0	4)		
			HBC-38/17	38/17	4)	23,0	24,3	26,3	4)	
			HBC-40/22(-N)	40/22		24,3	25,7	27,3		
			HBC-50/30(-N)	50/30	4)	4)	29,9	31,7	33,9	

- 1) In absence of other national regulations
- 2) Materials according to Table 6, Annex A6
- 3) Not applicable for HBC-28/15 and HBC-50/30
- 4) Product not available

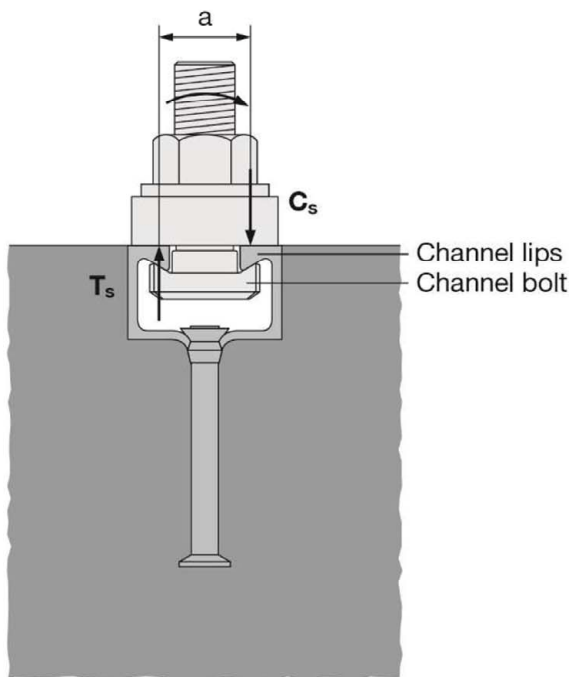

5) The characteristic flexure resistance according to Table 29 is limited as follows:

$$M^{0}_{Rk,s} \leq 0,5 \cdot N_{Rk,s,l} \cdot a \quad (N_{Rk,s,l} \text{ according to Table 11 and Table 12})$$

$$M^{0}_{Rk,s} \leq 0,5 \cdot N_{Rk,s} \cdot a \quad (N_{Rk,s} \text{ according to Table 29})$$

a = internal lever arm according to Table 29

T_s = tension force acting on the channel lip

C_s = compression force acting on the channel lip

Anchor channels (PEC-TA) with channel bolts (HBC)

Performance Data

Characteristic flexural resistances of channel bolts under shear load with lever arm

Annex C10

Table 30: Characteristic resistance $F_{Rd,s,fi}$ [kN] of anchor channels under fire exposure

Channel bolt		M10	M12	≥ M16	
Steel failure: Anchor, connection between anchor and channel, local flexure of channel lip					
Characteristic resistance in cracked concrete C20/25	PEC-TA 28/15	R60	0,8	2)	
		R90			
		R120			
	PEC-TA 38/17	R60	2)	1,9	
		R90			
		R120			
	PEC-TA 40/25 PEC-TA 40/22 (P)	R60	1,7	3,5	
		R90			
		R120			
	PEC-TA 49/30 PEC-TA 50/30 (P) PEC-TA 52/34	R60	2)	3,8	3,9
		R90			
		R120			
Partial factor		$\gamma_{Ms,fi}$ ¹⁾	[-]		
			1,0		

¹⁾ In absence of other national regulations

²⁾ No performance assessed

Table 31: Minimum axis distance of reinforcement

Anchor channel		PEC-TA 28/15	PEC-TA 38/17	PEC-TA 40/25	PEC-TA 40/22 (P)	PEC-TA 49/30	PEC-TA 50/30 (P)	PEC-TA 54/33	PEC-TA 52/34
Min. axis distance	R60	35				50	50	50	50
	R90	45							
	R120	55							

Fire exposure from one side only

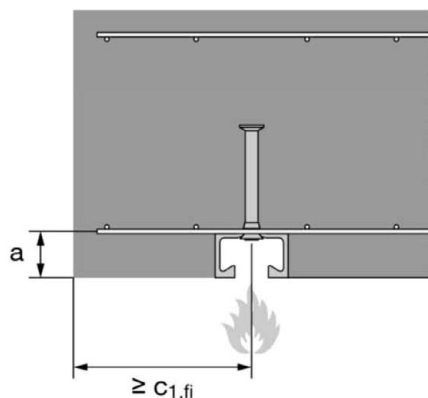

Fire exposure from more than one side

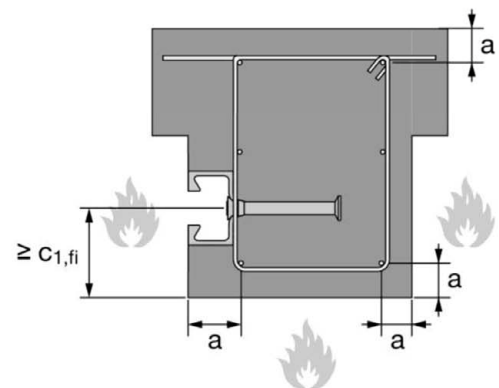

Anchor channels (PEC-TA) with channel bolts (HBC)

Performance Data

Characteristic resistances of anchor channels and channel bolts under fire exposure

Annex C11

Table 32: Combination of anchor channels and channel bolts under fatigue tension load

Anchor channel			Channel bolt			
Channel profile	Anchor type	Corrosion protection	Channel bolt	Diameter	Steel grade	Corrosion protection
PEC-TA 40/22 P	R	F	HBC-40/22	M12	8.8	G F
				M16		
PEC-TA 50/30 P			HBC-50/30	M16		
				M20		
PEC-TA 52/34			HBC-50/30	M16		
				M20		

Table 33: Characteristic resistances under fatigue tension load – steel failure after n load cycles without static preload ($N_{Ed} = 0$) (Design method I according to EOTA TR 050)

Anchor channel		PEC-TA 40/22 P	PEC-TA 50/30 P	PEC-TA 52/34
Steel failure	n	$\Delta N_{Rk,s,0,n}$ [kN]		
Characteristic resistance under fatigue tension load after n load cycles without static preload ($N_{Ed} = 0$)	$\leq 10^4$	16,4	20,9	24,3
	$\leq 10^5$	7,7	9,0	12,5
	$\leq 10^6$	3,2	4,2	7,1
	$\leq 2 \cdot 10^6$	2,6	3,7	6,4
	$\leq 5 \cdot 10^6$	2,2	3,4	5,9
	$\leq 10^8$	2,0	3,3	5,7
	$> 10^8$	1,8	3,2	5,5

Anchor channels (PEC-TA) with channel bolts (HBC)

Performance Data
Characteristic resistances under fatigue tension load

Annex C12

Table 34: Reduction factor $\eta_{c,fat}$ of characteristic fatigue resistance - concrete failure after n load cycles without static preload ($N_{Ed} = 0$) (Design method I according to EOTA TR 050)

Anchor channel		PEC-TA 40/22 P	PEC-TA 50/30 P	PEC-TA 52/34
Pull-out and Concrete cone failure	n	$\eta_{c,fat}$ [-]		
Reduction factor after n load cycles without static preload ($N_{Ed} = 0$) for: $\Delta N_{Rk,p,0,n} = \eta_{c,fat} \cdot N_{Rk,p}$ $\Delta N_{Rk,c,0,n} = \eta_{c,fat} \cdot N_{Rk,c}$ with $N_{Rk,p}$ calculated according to Annex C3 and $N_{Rk,c}$ calculated according to EOTA TR047, March 2018 or EN 1992-4: 2018	$\leq 10^4$	0,736		
	$\leq 10^5$	0,665		
	$\leq 10^6$	0,600		
	$\leq 2 \cdot 10^6$	0,582		
	$\leq 5 \cdot 10^6$	0,559		
	$\leq 6 \cdot 10^7$	0,500		
	$> 6 \cdot 10^7$	0,500		

Table 35: Characteristic resistances under fatigue tension load – steel failure with $n \rightarrow \infty$ load cycles without static preload ($N_{Ed} = 0$) (Design method II according to EOTA TR 050)

Anchor channel	PEC-TA 40/22 P	PEC-TA 50/30 P	PEC-TA 52/34
Steel failure	$\Delta N_{Rk,s,0,\infty}$ [kN]		
Characteristic fatigue limit resistance ($n \rightarrow \infty$) without static preload ($N_{Ed} = 0$)	1,8	3,2	5,5

Table 36: Reduction factor $\eta_{c,fat}$ of characteristic fatigue limit resistance - concrete failure with $n \rightarrow \infty$ load cycles without static preload ($N_{Ed} = 0$) (Design method II according to EOTA TR 050)

Anchor channel	PEC-TA 40/22 P	PEC-TA 50/30 P	PEC-TA 52/34
Pull-out and Concrete cone failure	$\eta_{c,fat}$ [-]		
Reduction factor for fatigue limit resistance ($n \rightarrow \infty$) without static preload ($N_{Ed} = 0$) for: $\Delta N_{Rk,p,0,n} = \eta_{c,fat} \cdot N_{Rk,p}$ $\Delta N_{Rk,c,0,n} = \eta_{c,fat} \cdot N_{Rk,c}$ with $N_{Rk,p}$ calculated according to Annex C3 and $N_{Rk,c}$ calculated according to EOTA TR047, March 2018 or EN 1992-4: 2018	0,5		

Anchor channels (PEC-TA) with channel bolts (HBC)

Performance Data

Characteristic resistances under fatigue tension load

Annex C13